

# ASSEMBLING YOUR GRISPORT BIKE CARRIER

## PARTS LIST

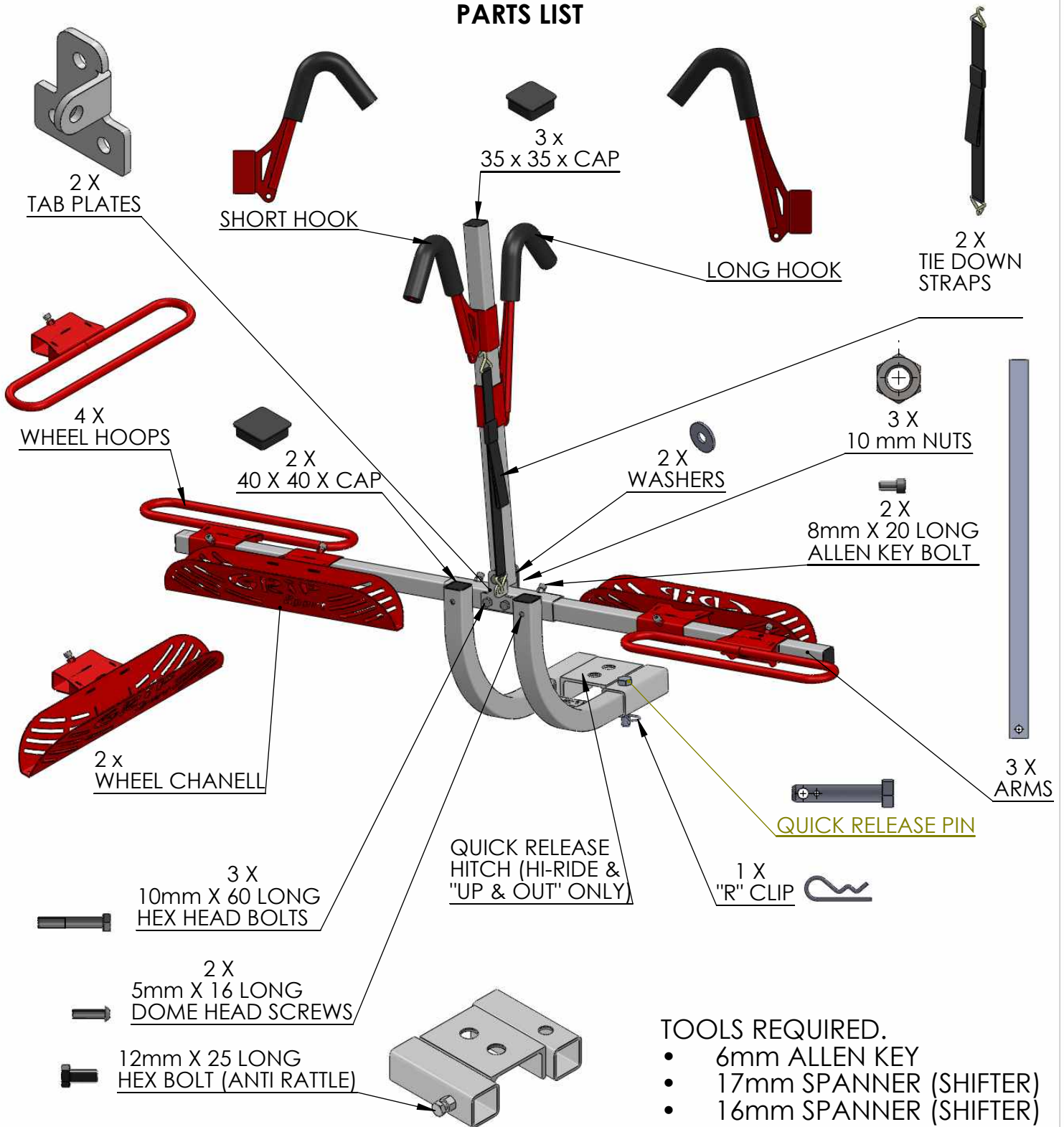

DEPENDING ON YOUR ORDER, YOU WILL RECEIVE ONE OF THE FOLLOWING FRAMES.  
( ASSEMBLY IS THE SAME FOR ALL)

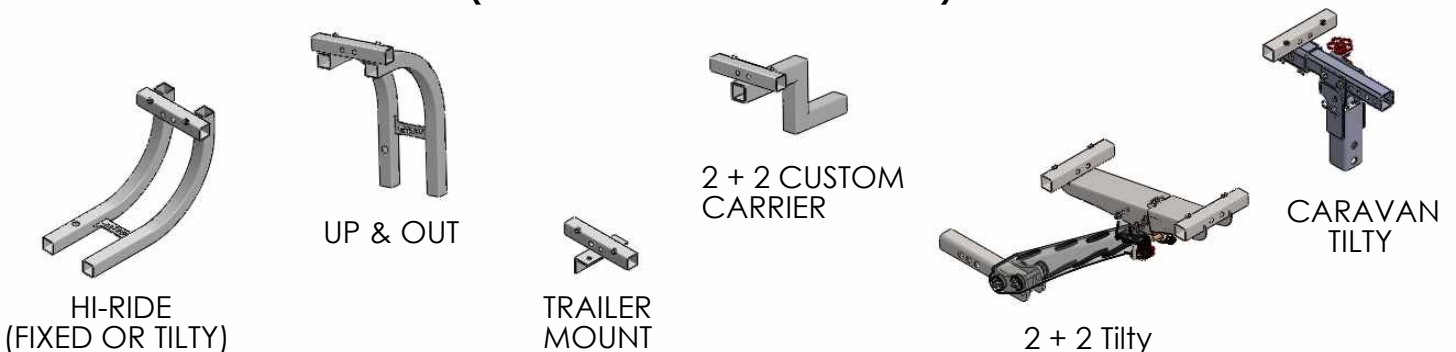

**STEP 1. FIT QUICK RELEASE HITCH TO YOUR TOW BAR TONGUE  
(Hi-Ride & Up & Out Carriers only)**

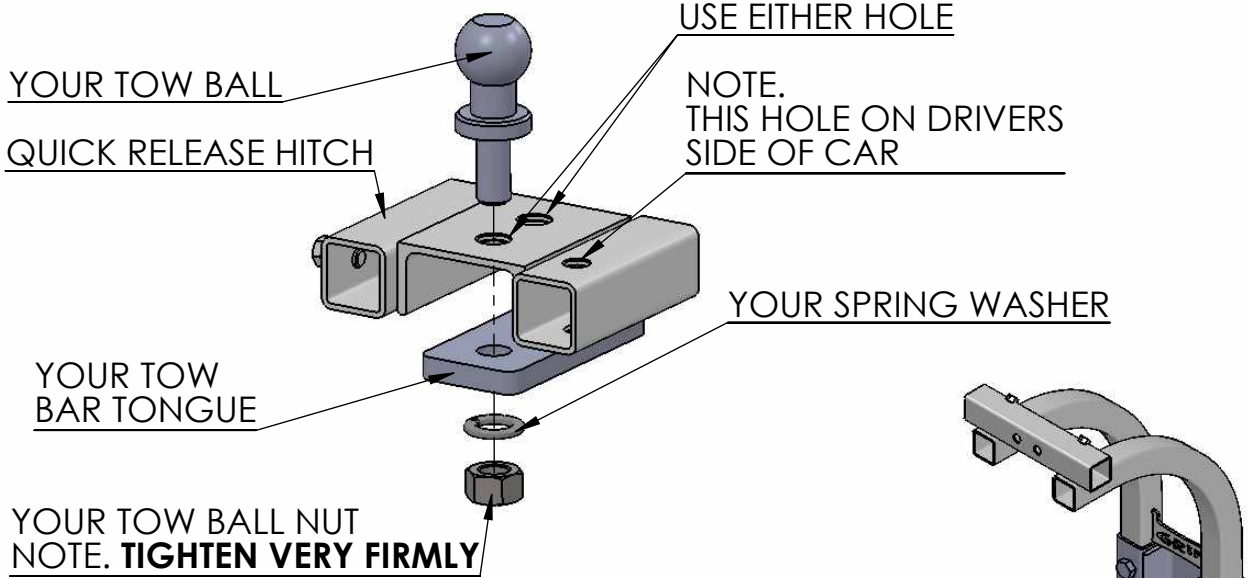

**STEP 2. INSERT FRAME IN TO QUICK RELEASE HITCH**

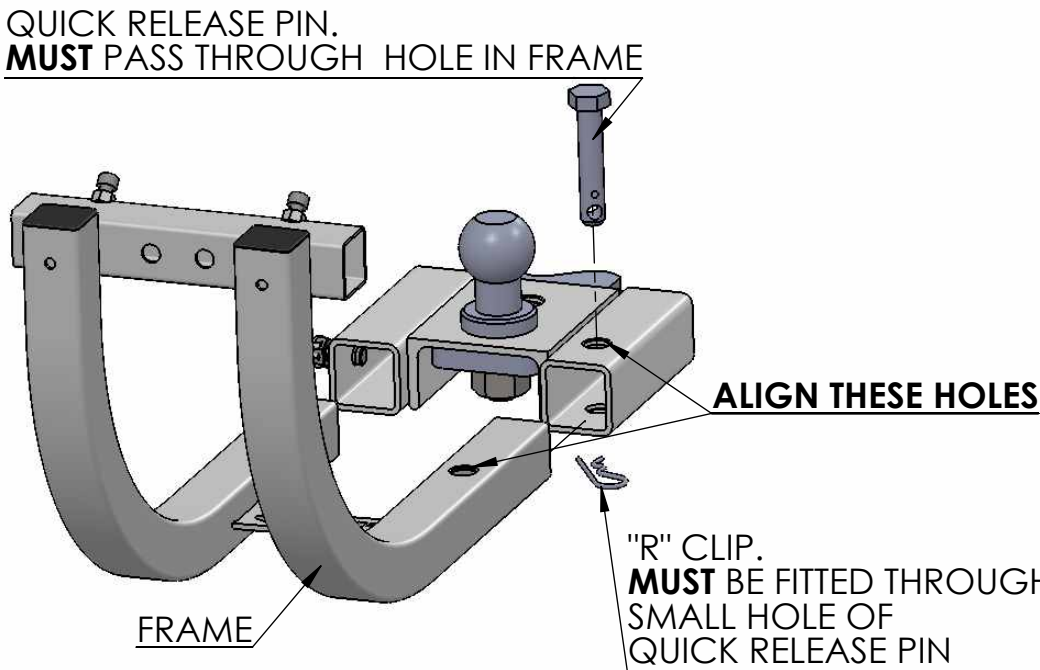

**STEP 3. ASSEMBLE PIVOT ARM**

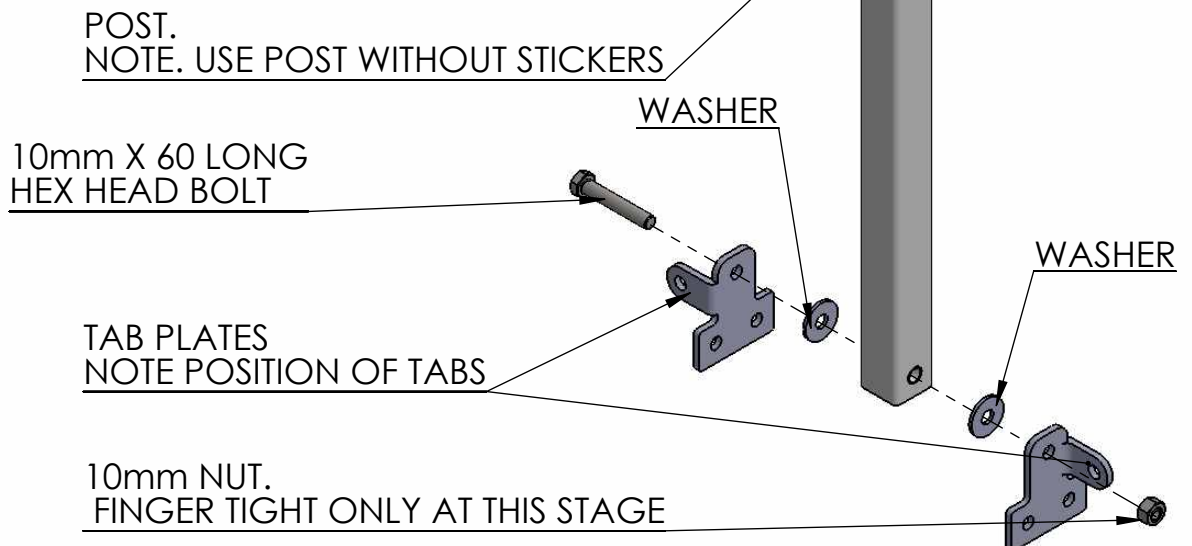

#### STEP 4. FIT SIDE ARM'S & PIVOT ARM TO FRAME

1. INSERT SIDE ARMS IN TO FRAME (**ENSURING HOLES ARE ALIGNED**)
2. PLACE PIVOT ARM ASSEMBLY OVER FRAME (**ENSURE HOLES ARE ALIGNED**)
3. INSERT 10MM X 60 LONG HEX HEAD BOLTS THROUGH ALL PARTS & FIT NUTS

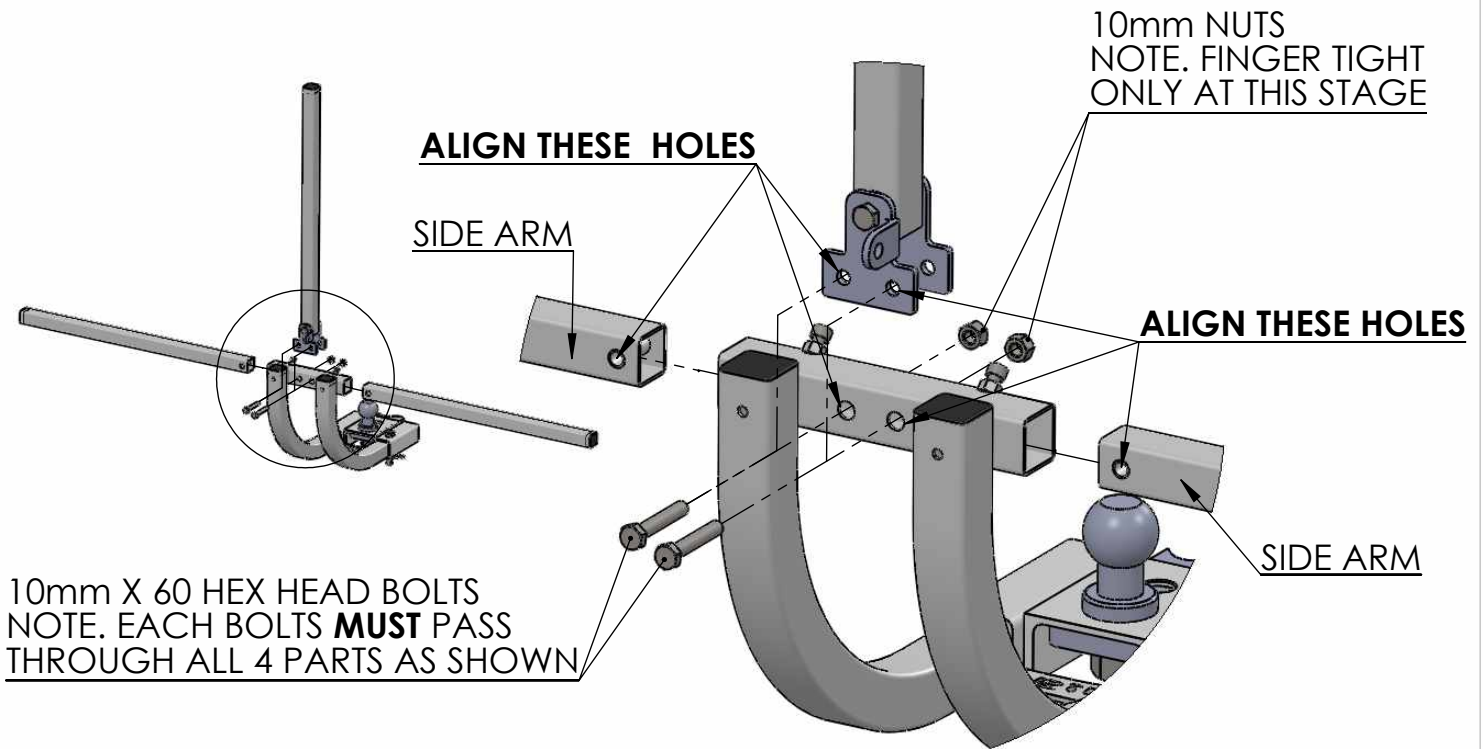

#### STEP 5. TIGHTEN ALL BOLTS IN CORRECT SEQUENCE

**FIRST**  
8MM X 20 LONG  
ALLEN KEY BOLTS  
**TIGHTEN THESE - VERY FIRMLY**  
(REQUIRES 6MM ALLEN KEY)

PIVOT ARM

**THIRD**  
10MM X 60 LONG HEX HEAD BOLT.  
(THIS WILL SECURE THE PIVOT ARM)

TIGHTEN UNTIL PIVOT ARM  
IS STIFF TO PIVOT  
FROM SIDE TO SIDE

**SECOND**  
10MM X 60 LONG  
HEX HEAD BOLTS  
**TIGHTEN THESE**  
(VERY FIRMLY)

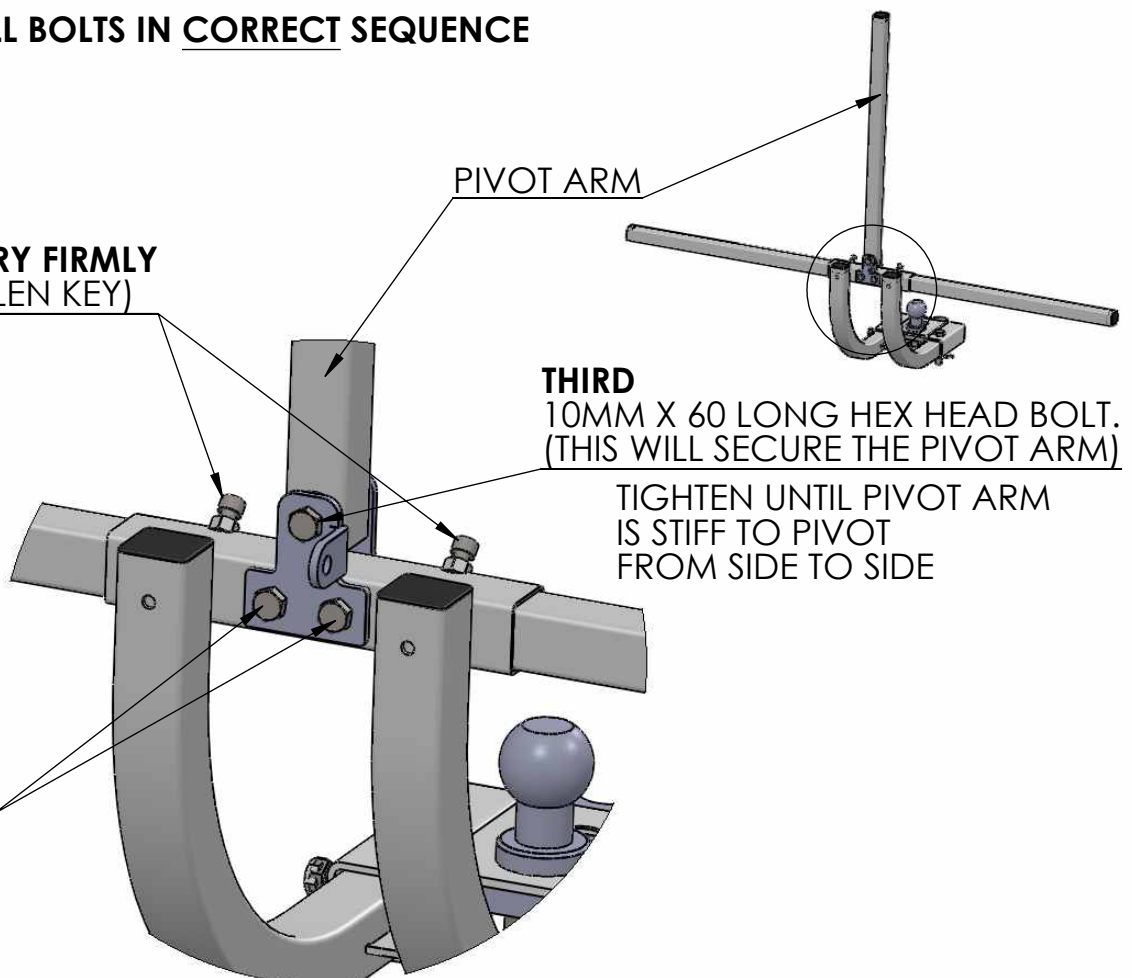

## STEP 6. FIT RACK-LIGHT (IF PROVIDED)

17MM LONG SPACERS  
(ONLY REQUIRED FOR  
HI-RIDE TILTY)

5MM X 16 LONG (DOME  
HEAD SCREWS  
(REQUIRES 3MM ALLEN KEY)

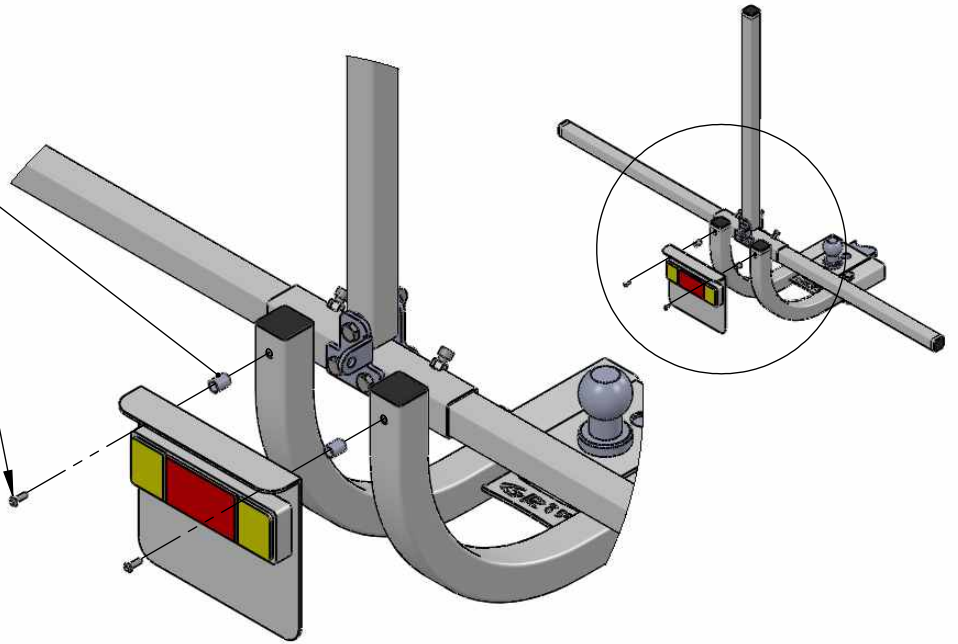

YOU HAVE NOW COMPLETED THE ASSEMBLY OF YOUR GRIPSPORT HI-RIDE CARRIER.

-----

## SETTING CARRIER UP FOR YOUR BIKES.

STEP 1. SLIDE WHEEL HOOPS & CHANNELS ONTO  
ARMS AS SHOWN.

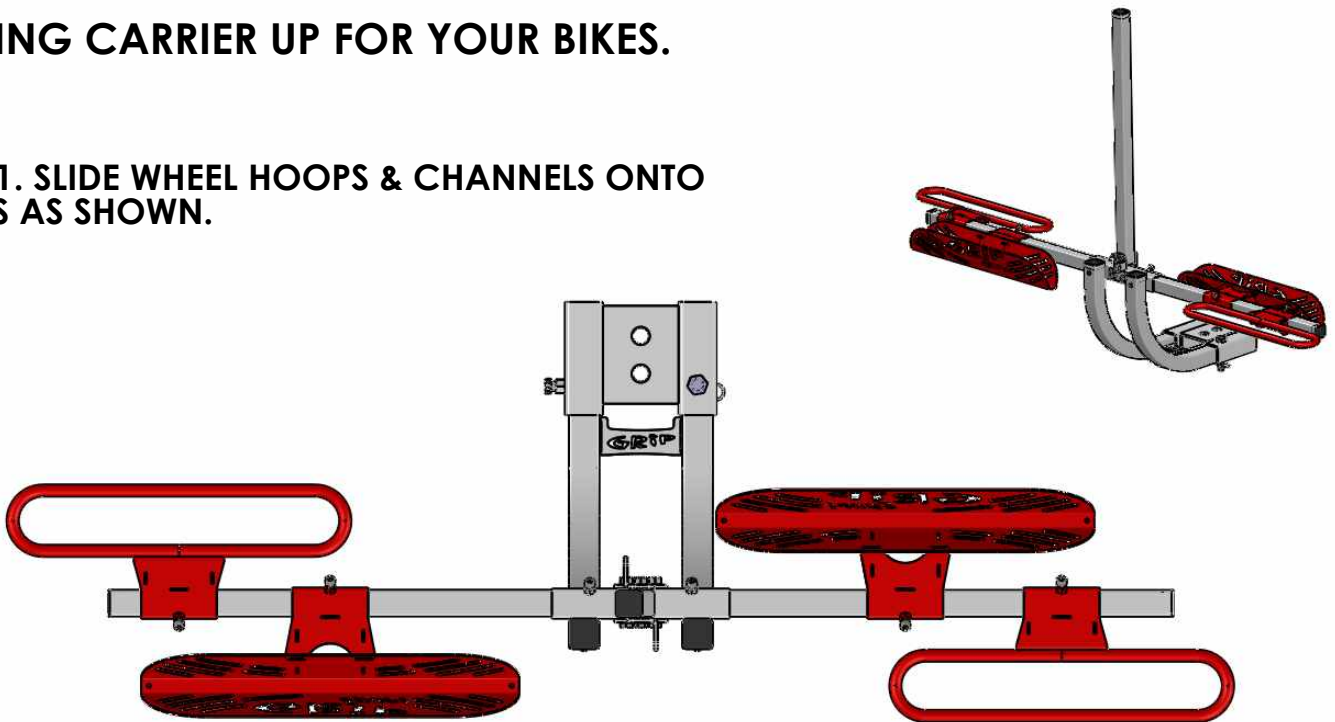

THIS CONFIGURATION WILL SUIT THE VAST MAJORITY OF BIKES.  
YOU MAY WISH TO ALTER THIS IF YOU NEED TO ACCOMMODATE BIKES WITH VERY  
DIFFERENT FRAME SIZES.

## STEP 2. ADJUST HOOPS & CHANNELS WITH OUR "SET & FORGET" BIKE POSITIONING

1. SET HOOPS & CHANNELS TO APPROXIMATE POSITION (EQUAL TO YOUR BIKE'S WHEEL BASE - AXLE TO AXLE)
2. PLACE BIKE ON RACK WITH FRONT WHEEL IN HOOP
3. FIT HOOK TO SUPPORT BIKE.
4. LOCK HOOPS & CHANNELS IN PLACE WITH ALLEN KEY



USE LONG HOOK FIRST

IF ONLY CARRYING ONE BIKE THE HOOK **MUST** BE PLACED AT THE LOWEST POINT ON THE TOP TUBE.

SOME STEP THROUGH FRAMES WILL REQUIRE A TOP TUBE ADAPTOR

REPEAT WITH SECOND BIKE & FIT TIE DOWN STRAPS AND TIGHTEN FIRMLY



FIT TIE DOWN STRAPS

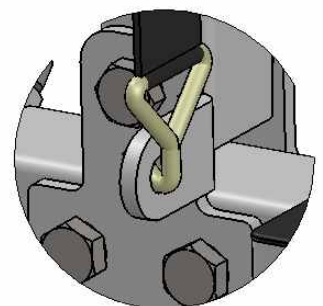
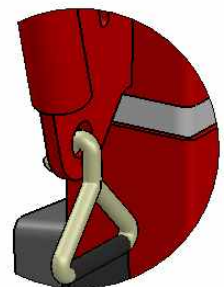

## LIVING WITH YOUR HI-RIDE CARRIER

THE QUICK RELEASE HITCH CAN BE LEFT ON THE TOW BAR (EXCEPT WHEN TOWING)  
REMOVING CARRIER FROM VEHICLE.

SIMPLY PULL OUT "R" CLIP, LIFT OUT QUICK RELEASE PIN AND SLIDE CARRIER  
OUT OF HITCH.

FITTING CARRIER TO VEHICLE.

SLIDE CARRIER FULLY INTO HITCH, FIT QUICK RELEASE PIN, INSERT "R" CLIP INTO  
SMALL HOLE IN PIN.

TIGHTEN ANTI RATTLE BOLT IF REQUIRED.

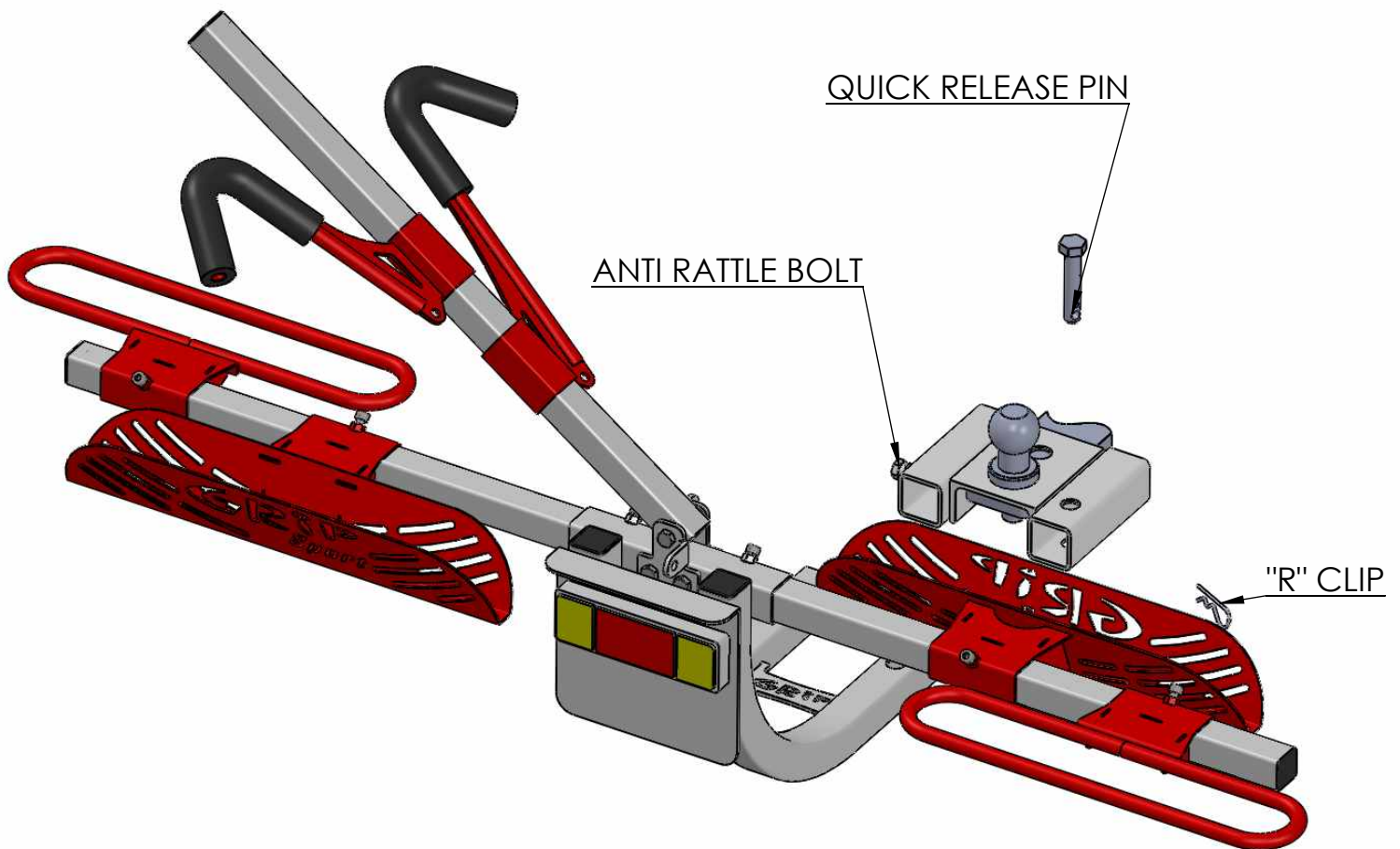

## IMPORTANT

NEVER USE CARRIER WITHOUT QUICK RELEASE PIN & "R" CLIP IN PLACE.

PERIODICALLY CHECK ALL BOLTS ARE FIRMLY TIGHTENED.